

# Instructions for wear checks of play equipment

The equipment must be checked for correct operation and safety, especially the points listed below:

Proof of maintenance

**Playground**.....

**Date of installation** .....

Checks depend on the type of equipment. Any equipment with moving parts must be checked at least twice a year, static equipment at least once a year.

Intervals for maintenance work and checks generally depend on

- the location
- the usage
- the frequency of use
- possible vandalism

For more details see also "General instructions for maintenance of playgrounds".

## Rotating Discs with stand post of stainless steel

- |  |  |
|--|--|
| <b>Order No. 10.22105</b><br>Spiral      | <b>Order No. 10.22505</b><br>Funnel 2    |
| <b>Order No. 10.22205</b><br>Funnel      | <b>Order No. 10.22605</b><br>Pulsation 2 |
| <b>Order No. 10.22305</b><br>Pulsation   | <b>Order No. 10.22705</b><br>Pulsation 3 |
| <b>Order No. 10.22405</b><br>Colour Disc | <b>Order No. 10.22805</b><br>Spiral 2    |

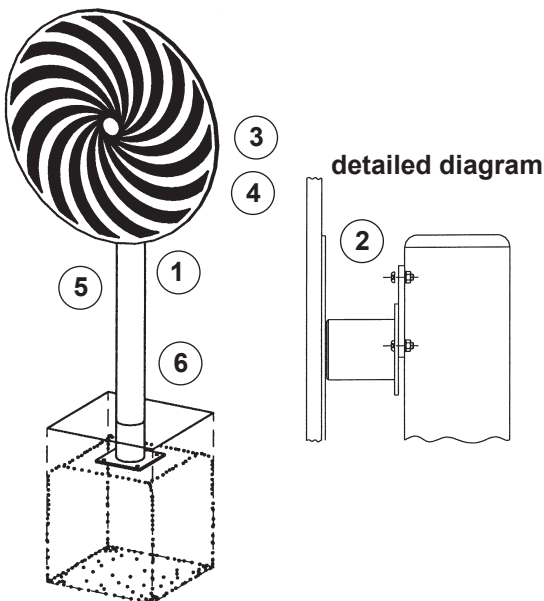

### Bearing

1. Check that disc moves smoothly.

### Disc

2. Check connection to the stand post for wear and tear and retighten bolts/screws if necessary (see detailed diagram).
3. Clean coated surface with car finish cleaner/protectant.
4. Cover up scratches with matching colour of acrylic paint.

### Stainless steel

5. Clean with stainless steel spray using a clean cloth.

### Structural stability

6. Check anchoring to the ground and stand post for corrosion once a year.

Special notes, e.g. for repairs

Repair not carried out, it is still possible to play on equipment

Repair not carried out, equipment is taken out of action

All work carried out, everything is in order

Maintenance carried out by:

For spare parts refer to back of page.

..... Date .....

**Spare Parts**  
**Rotating Discs**  
**Order No. 10.22105 -**  
**10.22805**

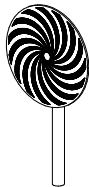

Please note that the safety standards of the equipment must not be affected. Therefore, when carrying out repairs it is helpful to **only use original parts.**

**Order No. Spare part**

10.99913 rotating disc

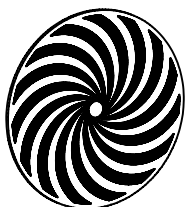

10.99919 stand post made of stainless steel

