



Order No. 3.12100 Small Triangular Hut

**Play value**

The Triangular Hut without combination equipment is a house for family role plays and other games on one or two levels. If the Hut is combined with a slide or other attractive play equipment, it represents a versatile "mini-playground" in limited space. The Triangular Hut is an unusual basic element which adds to the value of playgrounds.

**Fundamental characteristics**

- Child proportions according to ergonomic requirements
- One or two play levels
- Natural wooden surface which appeals to the senses
- Variable basic elements offering many opportunities for combination
- Incentive for playing: role games in small, cosy rooms
- Movement: climbing

**Recommended for**

- Kindergarten children
- Supervised play areas, such as kindergartens, schools, after-school programmes or similar
- Public play areas without supervision, such as playgrounds, parks or similar



Order No. 3.12300 Triangular Hut



Order No. 3.12300 Triangular Hut

**Huts for combination**

- Small Triangular Hut
- Triangular Hut



3.12100

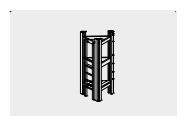

3.12300

**Order No. 3.12100**  
**Small Triangular Hut**

Safety distance   
Device dimensions   
Functional distance 

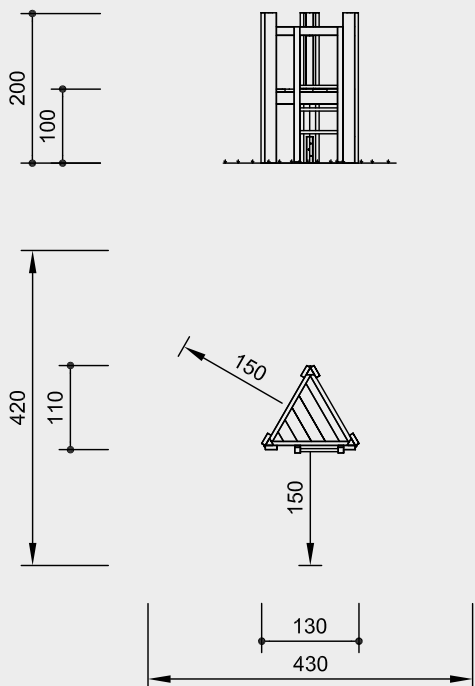

**Order No. 3.12300**  
**Triangular Hut**

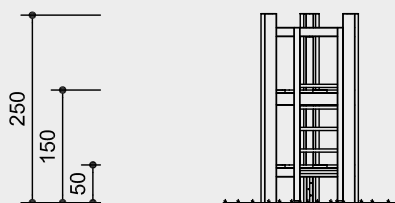

Scale 1:100

Safety check according to DIN EN 1176

**Components**

**Order No. 3.12100**  
**Small Triangular Hut**

- 3 side parts
- 1 ladder
- 1 floor
- 3 steel feet

**Order No. 3.12300**  
**Triangular Hut**

As above, but with 2 floors

**Installation information**

Surfacing requirements corresponding to a fall height of  
**Order No. 3.12100** ≤ 1.00 m  
**Order No. 3.12300** ≤ 1.50 m  
(please refer to price list for more detailed information)

Foundations  
3 items 40 x 40 x 40 cm  
Excavation depth 60 cm

**Attention:**  
**Exact measurements may vary;**  
**for all installation dimensions refer**  
**to current assembly instructions.**  
Technical changes reserved.

**Technical information**

Equipment made of non-impregnated mountain larch

**Core-free**

Sawn-timbers core-free, thus decreasing occurrences of cracking and undesired changes in shape



**Tongue and groove**

Tongue and groove planks made of 4 cm solid wood, highly resilient, no trickling of dust / sand, protection against direct rain



**Hardwood rungs**

Climbing rungs made of hardwood (ash) Ø 4.2 cm, milled and mortised, secured against twisting, easy to grip and not cold for children to touch



**Adjustable**

Adjustable two-piece bolt connection, easy to maintain, no projecting threads



**Ground anchor**

All parts used for anchoring to the ground are made of hot-dip galvanised steel or stainless steel



**For more detailed explanation of the quality characteristics see price list.**

**Dimensions**

(small deviations possible)

**Order No. 3.12100**  
**Small Triangular Hut**

Height	2.00 m
Floor height	1.00 m
Side length	1.30 m
Weight	190 kg

**Order No. 3.12300**  
**Triangular Hut**

Height	2.50 m
Floor heights	0.50 / 1.50 m
Side length	1.30 m
Weight	240 kg



3.12100



3.12300